

THIS DRAWING IS UNPUBLISHED. RELEASED FOR PUBLICATION . 19

© COPYRIGHT 19 BY AMP INCORPORATED, HARRISBURG, PA. ALL INTERNATIONAL RIGHTS RESERVED. AMP PRODUCTS MAY BE COVERED BY U.S. AND FOREIGN PATENTS AND/OR PATENTS PENDING.

REVISIONS						
P	F	ZONE	LTR	DESCRIPTION	DATE	APPROVED
C	✓		C	REV PER ECN AA-3115	6-25-86	SD

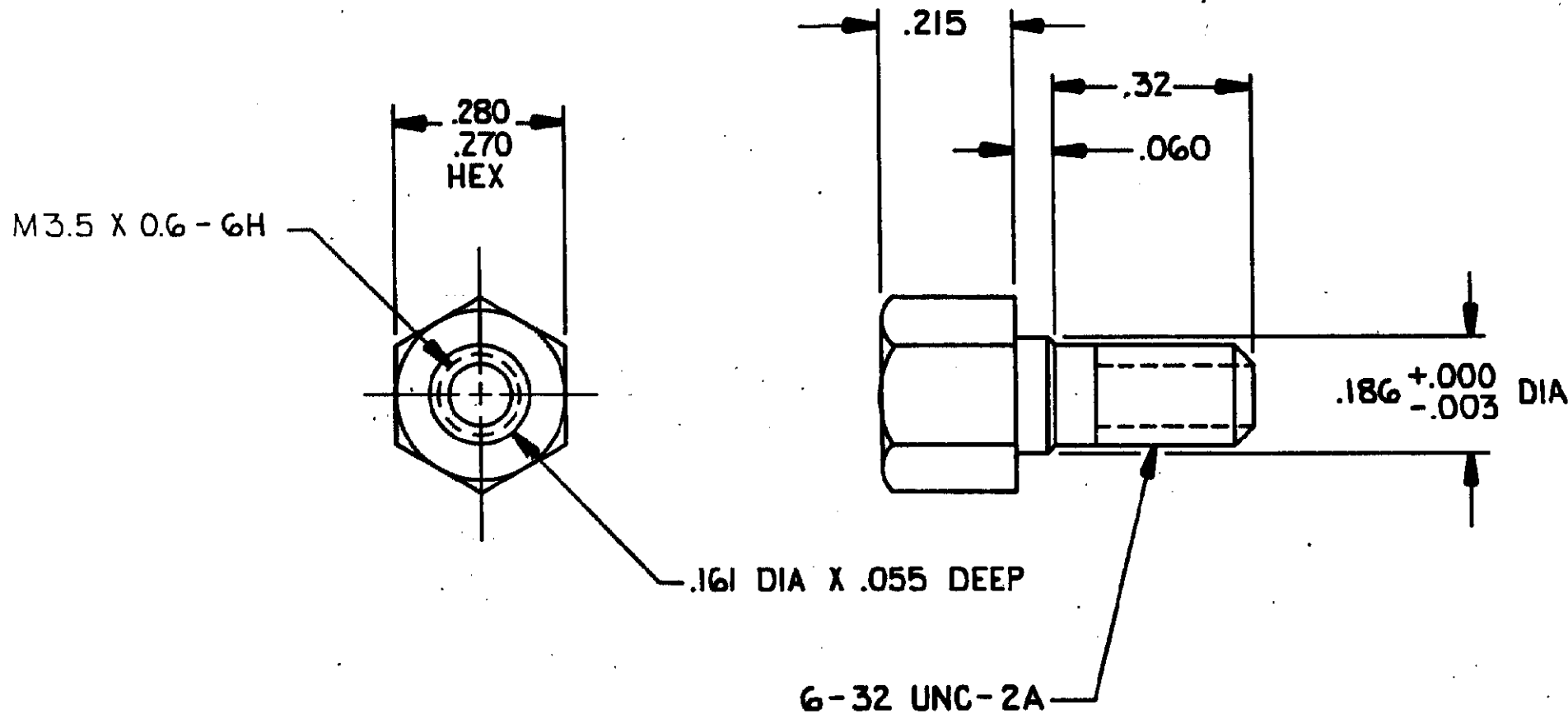

1. ALL DIMENSIONS SHOWN ARE MAXIMUM UNLESS OTHERWISE SPECIFIED.
2. MATERIAL: BLACK OXIDE COATED CARBON STEEL.
3. TWO OF EACH COMPONENT REQUIRED PER KIT.
4. ONE KIT SHIPPED PER POLY BAG.
5. PARTS COATED WITH AMP APPROVED CORROSION PREVENTATIVE.

554808-1

PART NO

UNLESS OTHERWISE SPECIFIED DIMENSIONS ARE IN INCHES. TOLERANCES ON: DECIMALS ± ANGLES ±	CONTRACT NO		<b>AMP</b>   AMP INCORPORATED Harrisburg, Pa.		
	DR	S. Pozebanchuk 4-2-85			
	MATERIAL	CHK J. Coanta 4-5-85	NAME		HARDWARE KIT, STANDOFF STUD, METRIC, CHAMP
	FINISH	APPD George J. Smith 4-5-85 APPD M. K. Antevich 4/5/85	SIZE	FSCM NO	DRAWING NO
	OSGN APPD	<b>B</b>	00779	554808	
	OTHER APPD	SCALE 4:1	SHEET 1 OF 1		

CUSTOMER DRAWING